



MADE IN THE USA

Related Products (each sold separately):

- BP-012: Bulk Dispenser - Double - Tall (shown below)
- BP-090: Bulk Dispenser - Triple - Tall
- BK314-0111: Bulk Dispenser - Quad - Tall



Product Description:

- Bulk Dispenser - Single - Tall
- Holds protective equipment or miscellaneous items in bulk
- One compartment
- Top loading, top and bottom dispensing
- Pivot hinge lid
- Keyholes for wall mounting
- Clear PETG Plastic

Primary Area for Product Usage:

- Anywhere bulk items are needed

Dispenses:

- Personal protection equipment or miscellaneous items in bulk

Product Specifications (overall external dimensions):

- 12.27"W x 17.03"H x 5.83"D (31.2 cm x 43.3 cm x 14.8 cm)
- 3.2 lbs (1.4 kg) - approximated

Mounting Specifications:

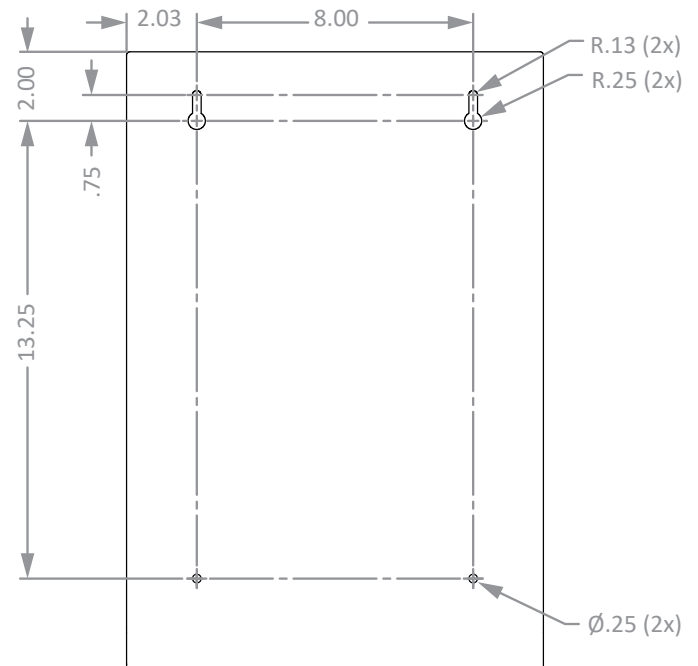

Package Specifications:

- Package Quantity: 1 per case
- 24"W x 16"H x 6"D (61.0 cm x 40.6 cm x 15.2 cm)
- 6.0 lbs (2.7 kg) - approximated





Installation

Always mount dispensers securely *prior* to loading with product.

- Product is loaded through the top and dispensed either through the top or bottom front.

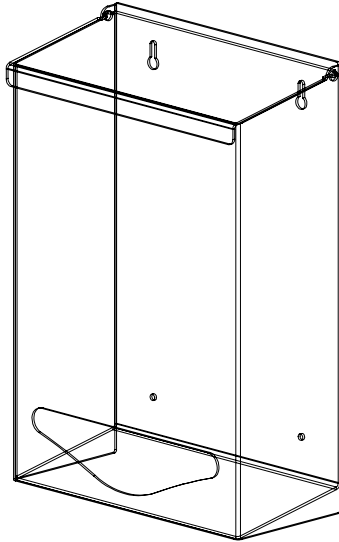

1

- Mount securely to a wall with screws approved and supplied by building maintenance.

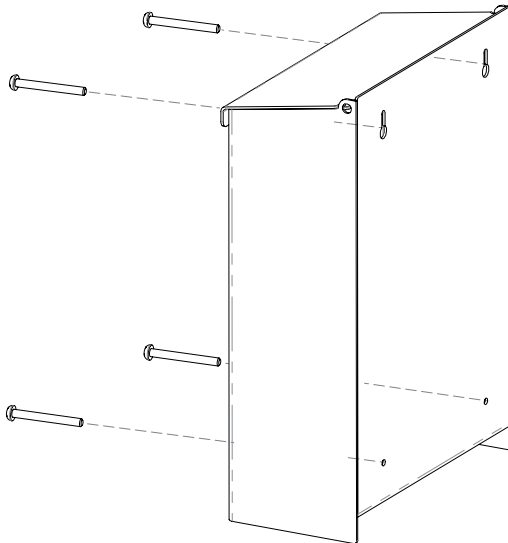

2

Parts included:

- Dispenser

Tools Required:

- No tools required to assemble dispenser

Care and Construction

PETG Plastic

Material Characteristics

Designed for Long-Term, Heavy-Duty Applications

Copolyester resin is designed for heavy-duty applications, and is used by BOWMAN® Dispensers. We never use acrylic in our products.

Copolyester (PETG) is typically 15-20 times tougher than general purpose acrylic. PETG is made to withstand handling and reduce losses due to breakage.

PETG resists a variety of chemicals and commonly used cleaning agents. It is tough and durable (not brittle), providing years of trouble-free functionality and long life.

Clear optical characteristics mean the viewer can see the content, read text, and see true colors through the material. It complies with FDA regulations for food contact.

Care and Cleaning

Most cleaning chemicals do not weaken the surface or cause damage to the material. Suggested cleaning method is to use a soft cloth, warm water, and mild soap.