



MADE IN THE USA

Related Products (each sold separately):

- GL003-0413: Glove Box Dispenser - Triple with Dividers (shown below)
- GL004-0413: Glove Box Dispenser - Quad with Dividers



Product Description:

- Glove Box Dispenser - Double with Divider
- Holds two boxes of gloves
- Two-way keyholes for vertical or horizontal mounting
- White Powder-Coated Steel

Primary Area for Product Usage:

- Anywhere gloves are needed

Dispenses:

- Box(es) no larger than 5.24"W x 10.00"H x 3.75"D (13.3 cm x 25.4 cm x 9.5 cm)
- Box(es) no smaller than 4.25"W x 9.00"H x 3.00"D (10.8 cm x 22.9 cm x 7.6 cm)

Product Specifications (overall external dimensions):

- 10.60"W x 10.03"H x 3.82"D (26.9 cm x 25.5 cm x 9.7 cm)
- 2.3 lbs (1.0 kg) - approximated

Mounting Specifications:

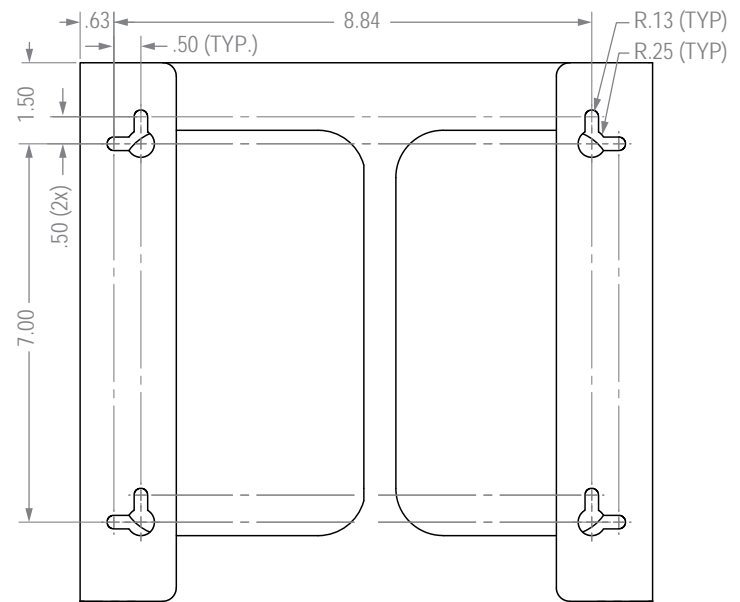

Package Specifications:

- Package Quantity: 6 per case
 - 16"L x 12"W x 12"H (40.6 cm x 30.5 cm x 30.5 cm)
 - 16.0 lbs (7.3 kg) - approximated
- Package Quantity: 1 per case
 - 12"L x 10"W x 9"H (30.5 cm x 25.4 cm x 22.9 cm)
 - 4.0 lbs (1.8 kg) - approximated





Installation

Always mount dispensers securely *prior* to loading with product.

- A divider keeps boxes separate for easy removal and stocking even when mounted horizontally.

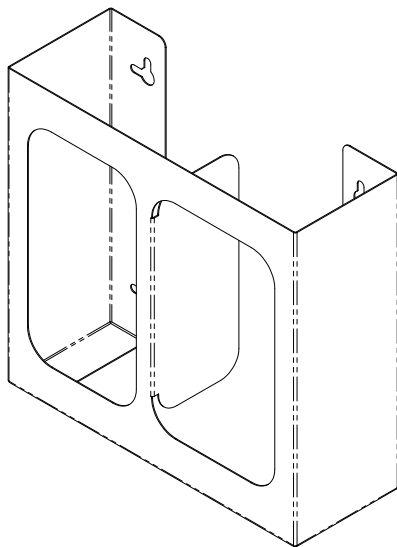

- Mount securely to a wall with screws approved and supplied by building maintenance.

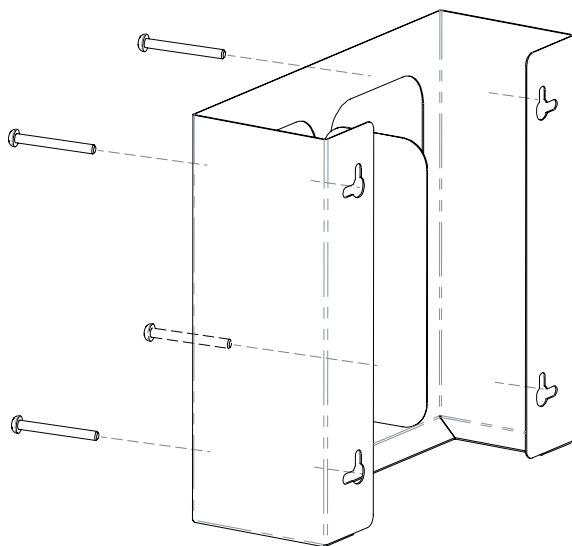

Parts included:

- Dispenser

Tools Required:

- No tools required to assemble dispenser

Care and Construction

Powder-Coated Steel

Material Characteristics

Designed for Long-Term, Heavy-Duty Applications

Dispensers and stands made of powder-coated steel are both attractive and functional, providing years of service. Our powder-coated steel dispensers and stands provide long-lasting products that hold up well in tough environments.

Powder-coated steel is ideal for dispensers used in a healthcare or an industrial setting. It is impact resistant and is not effected by extremes in temperature.

Care and Cleaning

The powder-coated finish resists common chemicals and cleaning agents and can be easily wiped clean with soap and water.